

		JAMESTOWN, MICHIGAN USA	
<small>The contents of this document are provided on a restricted basis and are not to be used in any way detrimental to the interests of KC Racing. Copyright © KC Racing. All rights reserved.</small>			
<small>Tolerances +/- .005 [0.13] unless noted</small> <small>Primary units - inches, metric [mm]</small>			
CarbonX Voltan Flexi Center Section			
<small>DATE</small> KCL	<small>DATE</small> 11/06/24	<small>VERSION</small>	
<small>QUANTITY</small> 	<small>SIZE</small> B	<small>NUMBER</small> KCR-CFVC	<small>SHEET</small> 1 OF 1

For repairs or adding parts to the carbon fiber:

Do not use standard CA "Super" Glue it is too brittle use a Carbon & Rubber Toughened Cyanoacrylate without an accelerator
 we recommend
 Bob Smith Industries IC-2000
 www.bsi-inc.com

Cleaning Carbon Fiber:

Use a gentle cleanser or soap, avoid acidic or harsh chemicals. Rinse with water. You will want to dry carbon fiber immediately after washing and avoid letting water sit on carbon fiber parts until it evaporates. This causes hard water spots. Use a soft, microfiber towel to dry your parts to avoid scratching the surface.

Fasteners Used:

M2 x 0.4 x 4mm long flathead screws with a head diameter of 3mm
 M2 x 0.4 hex nuts

Maximum torque: 1.77 lb-in [0.2Nm]
 No thread lock adhesive is recommended or used.

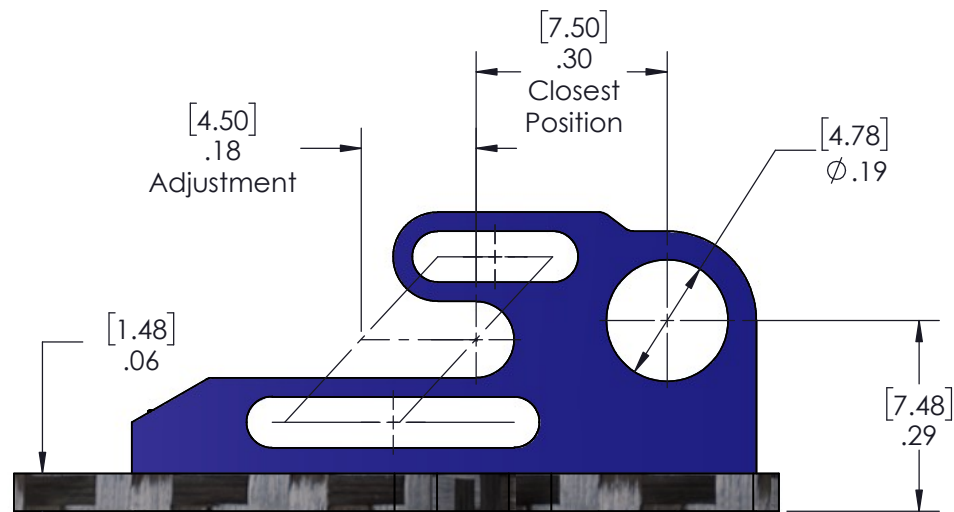

Motor Mount Detail

for gear selection
 designed for 9mm x 9mm mounting
 (Loctite 680 may be used to install bearings or bushings into support.)

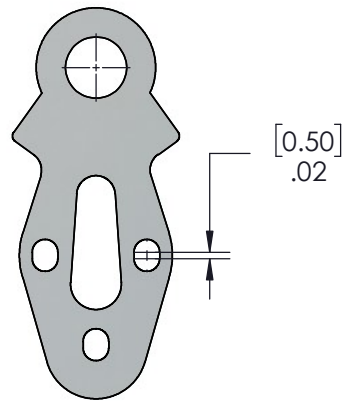

Guide Adjustment
 There is a slight adjustment in the guide mount

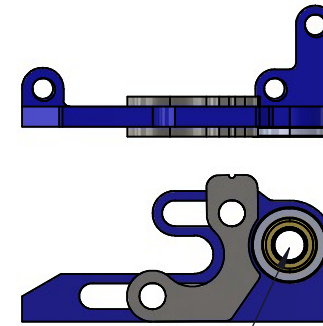

Bearing or bushing should be installed with Loctite

KCR-CFMS
 As installed
 (optional)

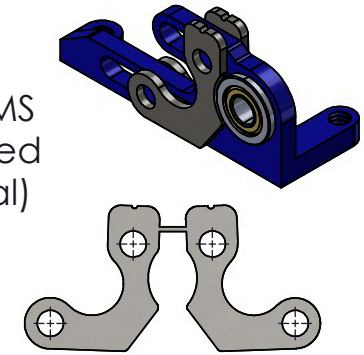

KCR-CFMS
 Motor Spacer
 as purchased

IMPORTANT
BLDC Installation

The motor mount design deployed in the CarbonX chassis requires the removal of the motor e-clip and spacer. Use of KCR-CFMS between the mount and the motor allows the e-clip and spacer to be left installed on the motor.

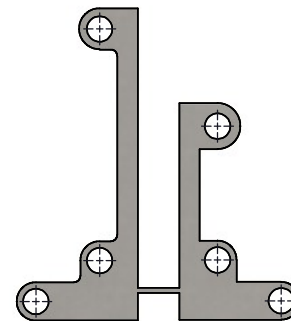

OPTIONAL: KCR-ASM
Rear Axle Shim Kit
 to lower the chassis 0.15" [.381] when using large tires

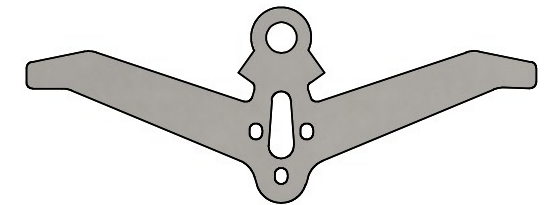
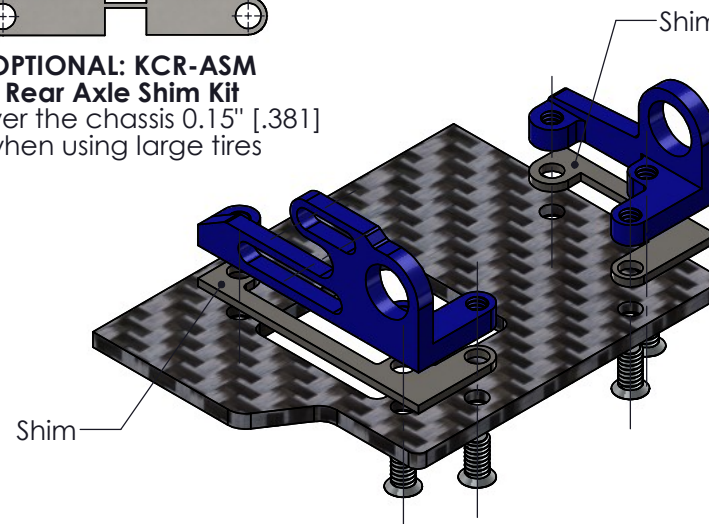

OPTIONAL: KCR-BGB
Guide / Bumper
 used on one piece flexi chassis adds 5 grams to chassis front

		JAMESTOWN, MICHIGAN USA	
The contents of this document are provided on a restricted basis and are not to be used in any way detrimental to the interests of KC Racing. Copyright © KC Racing. All rights reserved.			
Tolerances +/- .005 [0.13] unless noted Primary units - inches, metric [mm]			
Carbon Fiber Chassis Supplement			
DATE	REV	DATE	REV
KCL	10/11/24		
PART NAME / DESCRIPTION		REV	NUMBER
		B	KCR-CF SUP
			SHEET 1 OF 1